

Blast Chillers CW

Blast Chiller Crosswise 56kg (R452A)

ITEM # _____

MODEL # _____

NAME # _____

SIS # _____

AIA # _____

727892 (RBC20156)

 Blast Chiller 56kg,
 compatible with 20x1/1 GN
 crosswise Oven - R452A

Short Form Specification

Item No. _____

- Blast chiller with digital temperature and time display
- For 20 GN 1/1 or 600x400 mm trays
- Load capacity: chilling 56 kg (UK guidelines)
- Single sensor core probe
- Operating air temperature: +3 -12°C
- Automatic and manual defrosting
- Turbo cooling function
- Specific cycles for ice cream
- Evaporator with antirust protection
- HACCP and Service alarms with data logging
- Main components in 304 AISI stainless steel
- Internal rounded corners and drain
- Cyclopentane insulation (HCFC, CFC and HFC free)
- Built-in refrigeration unit
- R452a refrigerant gas (HCFC and CFC free)
- Performance guaranteed at ambient temperatures of 40°C

Main Features

- Soft Chilling (air temperature -2°C).
- Hard Chilling (air temperature -12°C).
- Holding at 3°C for chilling, automatically activated at the end of each cycle, to save energy and maintain the target temperature (manual activation is also possible).
- Turbo cooling: chiller works continuously at the desired temperature; ideal for continuous production.
- Control unit provides two large displays to read out: time, core temperature, cycle countdown, alarms, service information.
- Two customizable cycles (P1 & P2) for each operating mode, allowing to set the time and air temperature. These programs can be converted into ice-cream specialized cycles (shape maintenance and holding).
- All information related to the different operating models are recorded: date, time, cycle, core temperature, holding temperature, HACCP accordance.
- Single sensor core probe as standard.
- Remaining time estimation for probe-driven cycles based on artificial intelligence techniques (ARTE) for an easier planning of the activities.
- Performance guaranteed at ambient temperatures of +40°C.
- Blast Chilling cycle: 56 kg from 90°C up to 3°C in less than 90 minutes.
- Automatic and manual defrosting.

Construction

- High density polyurethane insulation, 60 mm thickness, HCFC free.
- Ventilator swinging hinged panel for access to the evaporator for cleaning.
- No water connections required.
- Waste water can be plumbed into drain, but can also be collected in an optional waste container.
- Environmentally friendly: R452a as refrigerant gas.
- Built-in refrigeration unit.
- Removable magnetic door gasket with hygienic design.

APPROVAL: _____

Included Accessories

- 1 of 1 single-sensor probe for blast chiller and blast chiller&freezers PNC 880213
- 1 of Removable tray support rack for 20 GN 1/1 PNC 881010

Optional Accessories

- Connectivity kit for AOC/EasyLine and CW Blast Chillers/Blast Chiller Freezers (ECAP) PNC 880183
- 1 single-sensor probe for blast chiller and blast chiller&freezers PNC 880213
- Rilsan grid 600x400mm PNC 880864
- Removable tray support rack for 20 GN 1/1 PNC 881010
- Plastic coated grid, 1/1GN PNC 881061
- Rack rails for vertical blast chiller and blast chiller&freezer PNC 881182
- Pair of 1/1GN AISI 304 stainless steel grids PNC 921101
- Trolley for 20x1/1GN roll-in rack PNC 922132
- KIT HACCP EKIS PNC 922166
- 60mm pitch roll-in rack for 20x1/1GN (included with the oven) PNC 922203
- 80mm pitch roll-in rack for 20x1/1GN PNC 922205
- Ethernet connector for ECAP protocol appliances PNC 922768

Front

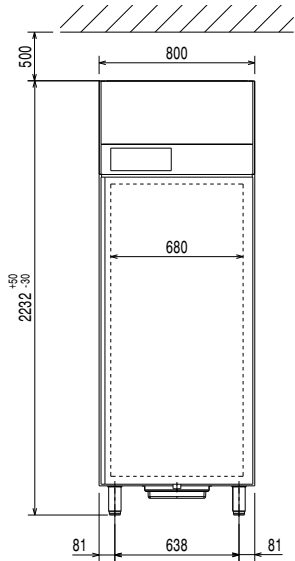

Side

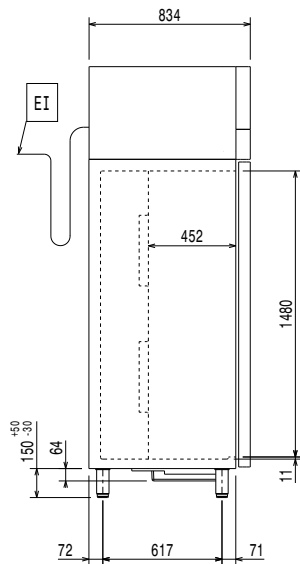

EI = Electrical inlet (power)

Top

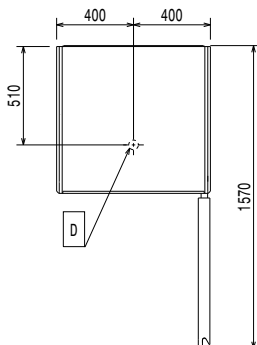

Electric

Supply voltage:
 727892 (RBC20156) 380-415 V/3N ph/50 Hz
Electrical power max.: 2.45 kW
Circuit breaker required

Installation:

Clearance: 5 cm on sides and back.
 Please see and follow detailed installation instructions provided with the unit

Capacity:

GN: 20 - 1/1 containers
Max load capacity - trays h 65 mm - n°: 12

Key Information:

External dimensions, Width: 800 mm
External dimensions, Depth: 835 mm
External dimensions, Height: 2230 mm
Net weight: 231 kg
Shipping weight: 238 kg
Shipping volume: 1.83 m³

Refrigeration Data

Refrigeration power at evaporation temperature: -5 °C

Product Information (EN17032 - Commission Regulation EU 2015/1095)

Chilling Cycle Time (+65°C to +10°C): 119 min
Full load capacity (chilling): 65 kg

Sustainability

Refrigerant type: R452A
GWP Index: 2141
Refrigeration power: 5363 W
Refrigerant weight: 2400 g
Energy consumption, cycle (chilling): 0.067 kWh/kg